

GC880 Wall-Mounted Gas Detection Controller

- Designed with the latest international technology
- The GC880 is manufactured in accordance with the EN European standards
- The GC880 can be used with explosion-proofed GC710 and GC720 and compatible with other compatible fixed gas detectors.

Features

- **Ease to operate**
 - Detect 4 or 8 channels simultaneously
 - Simultaneous display of all information of all tested channel
 - Real time alarm, 3 cell phone numbers can be set to receive site status at alarms(optional)
 - Supply power: 220V DC or 24V DC
 - Ultra-large LCD display screen
 - Protection class: IP 66
 - Rugged complete steel casing
- **Cost effective**
 - Competitive price
 - Easy training
 - Low installation cost
 - Reduced maintenance cost
- **High performance**
 - Self test on start
 - Main and standby power overload protection
 - Short circuit protection
 - Standby power seamless auto switch function
 - Continuous detection
 - 4-20mA signal output, available for manifold transmitters
 - Short message module(optional)
 - Strong electromagnetic shielding
 - Input voltage: 250V AC, 3A
 - Output voltage: 24V AC
 - Communication port: RS485/Message output for short message module (optional)
 - Consumption: 120W
- **Warranty**
 - 1 year



Exploded View

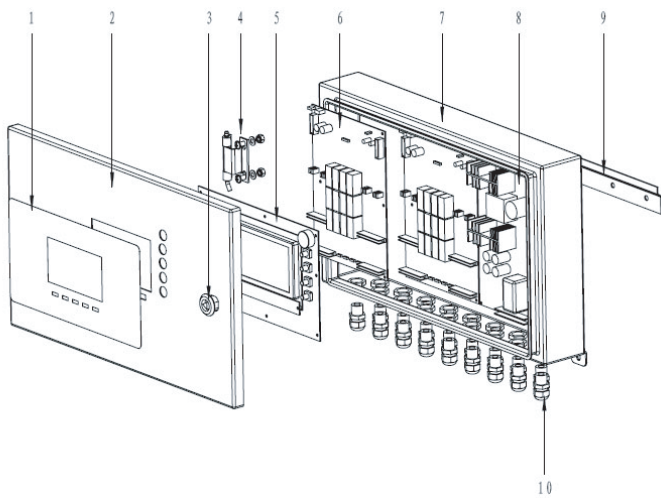

ITEM	DESCRIPTION	ITEM	DESCRIPTION
1	Screen protector	6	Channel board
2	Upper shell	7	Bottom shell
3	Upper shell lock	8	Power board
4	Hinge	9	Mounting plate
5	Main board	10	Inlet connector

Dimensions

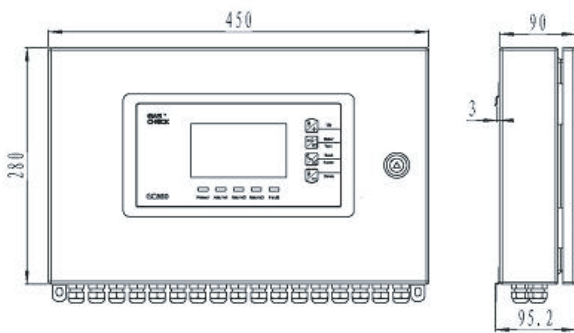

Installation

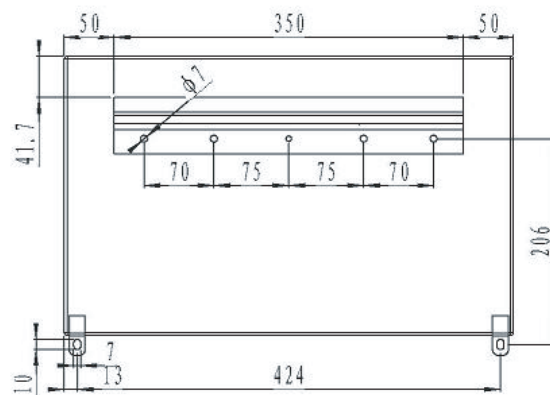

Terminal Blocks

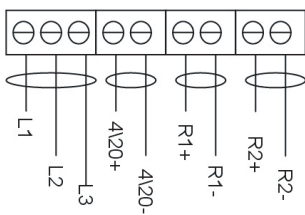

ITEM	Channel terminal
L1	Signal terminal(c/w detector)
L2-	24V negative pole(c/w detector)
L3	24V positive pole(c/w detector)
4/20+	Analog signal terminal
4/20-	Analog signal terminal
R1+/R1-	First class alarm terminal
R2+/R2-	Second class alarm terminal

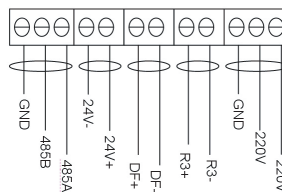

ITEM	Channel terminal
GND	Digital signal earthing
485B	Digital signal terminal B
485A	Digital signal terminal A
24V-	Negative pole of 24V power
24V+	Positive pole of 24V power
DF	Fault alarm
R3	3 grades public alarm
GND	Power earthing terminal
220V	220V power

Order Information

P/N	Product	P/N	Product	P/N	Product
A4911080+	4 channel controller	A4911080+	8 channel controller	A412222	Short message module
1*A412110		2*A412110			
A412110	Channel board	A412114	Power board	A412115	Main board